



# MOTORTRONICS™

Solid State AC Motor Control

# MWH Series

10 to 80 Amp Models  
Heater Controller

## INSTALLATION & STARTUP MANUAL



## Table of contents

<b>1 General Information .....</b>	<b>3</b>
1.1 Description .....	3
1.2 Features.....	3
1.3 Specifications .....	4
1.4 Receiving and Unpacking .....	4
1.5 Dimensions .....	4
<b>2 Installation .....</b>	<b>5</b>
2.1 Wiring.....	5
<b>3 Operation .....</b>	<b>8</b>
<b>4 Diagrams.....</b>	<b>9</b>
4.1 MWH 10 Amp Model.....	9
4.2 MWH 25 Amp Model.....	10
4.3 MWH 50 Amp Model.....	11
4.4 MWH 80 Amp Model.....	12
<b>WARRANTY INFORMATION .....</b>	<b>13</b>

## Chapter 1 - General Information

### 1.1 Description

The Motortronics **MWH Series** Solid State Motor Winding Heater is designed to prevent condensation build-up by applying a low level current to the AC motor windings when the motor is in the “off” condition. Motor windings are susceptible to condensation formation each time the motor is stopped and the windings’ temperature drops below the dew point. Over a period of time this condensation build- up can degrade the insulation of the windings and cause a short circuit when the motor is started. The same problem can occur when motors are not operated for an extended period of time. This is especially true for damp and humid locations.

### 1.2 Features

#### Fully Automatic Operation

The Motortronics **MWH Series** is designed for fully automatic operation. It turns on approximately one minute after it receives power. When the motor is started the MWH is instantly turned off. The MWH turns back on approximately one minute after the motor is turned off.

#### Overload Sensing

With the optional overload sensing, the MWH can be disabled automatically when a motor overload trip occurs. The heater will go back on-line automatically after the overload is reset. This prevents additional motor heating when a trip occurs providing faster motor cool down after a thermal overload trip condition.

#### LED Status Display

Indicator lights on the MWH inform the operator of the unit status. The POWER ON indicator shows that the power is on and both of the MWH fuses are good. The ENABLE indicator shows that the motor is off and the MWH control interlock is closed. The OUTPUT ON indicator shows that the MWH is supplying power to the motor windings.

#### Designed for Safety

The **MWH Series** is supplied in a compact open chassis design. Optional NEMA 1 enclosures are also available. The front cover of the unit is fiber- glass insulation material which shields against accidental contact with electrically live parts.

### 1.3 Specifications

MODEL	MAX AMP RATING	MOTOR HORSEPOWER RANGE			
		208V	240V	480V	575V
MWH-10	10	3 - 40	5 - 50	10 - 100	15 - 125
MWH-25	25	50 - 100	60 - 125	125 - 250	150 - 300
MWH-50	50	125 - 200	150 - 250	300 - 500	350 - 600
MWH-80	80	250 - 300	300 - 400	600 - 800	700 - 900

Table 1

**Adjustments:** Output voltage is factory set to provide sufficient power to the motor to maintain a +5° to 10°C differential above ambient temperature which is suitable for most applications. This adjustment can be used to trim the control as required for each application.

**Fusing:** Two fuses protect the MWH.

**Transient Protection:** An RC snubber circuit across the SCR protects it from rapid rate of change in the system voltage. A metal oxide varistor (MOV) protects the unit against voltage spikes on the line.

### 1.4 Receiving and Unpacking

**Unpacking** - Carefully unpack the unit from the shipping carton and inspect it for shipping damages. Immediately report any damages to the carrier.

**Mounting** - Select mounting location and make sure ambient temperature does not exceed operating range limits given in specifications. Allow for sufficient clearance on all sides of the unit.

### 1.5 Dimensions

Dimensions are in inches.

MODEL	OPEN PANEL			NEMA1 (N)		
	H	W	D	H	W	D
MWH-10	6.2	4.5	6	11	7	7
MWH-25	8	6	6	11	7	7
MWH-50	10	8	7.9	15	10	8
MWH-80	10	8	8	20	10	10

Table 2

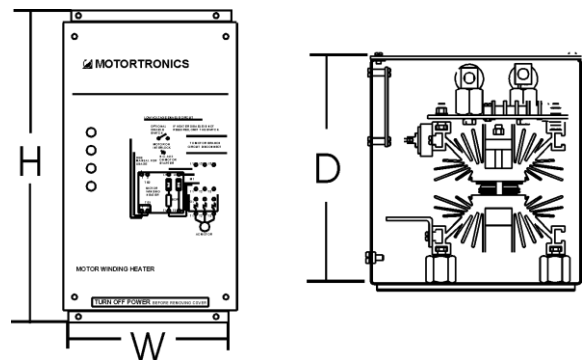

## 2.0 - Installation

### 2.1 Wiring

Connection diagrams illustrate typical wiring connections. Use 75° C minimum wires.

**Note: All wiring must comply with local codes, regulations and ordinances.**



**WARNING!**

**Do not service equipment with voltage applied. Unit can be the source of fatal electrical shocks.**

1. Mount the MWH on a vertical panel with the line connection (L1, L2) at the top. Proper orientation is required to achieve proper convection cooling of the solid state power device (SCR).
2. Remove the front cover of the winding heater for access to the power and control connections.
3. Recommended fuse and power wire sizes for MWH:

MAXIMUM MWH AMP	WIRE SIZE TYPE AWG	REPLACEMENT FUSE	
		F1	F2
10	14	Class T 600V 15 A	Class CC 20A Time Delay
25	8	Class T 600V 30 A	Class T 600V 70A
50	6	Class T 600V 60 A	Class T 600V 100A
80	2	Class T 600V 100 A	Class T 600V 150A

**Table 3**

TORQUE LB/IN				
MWH	L1	L2	T1	T2
10	20	20	45	20
25	20	50	50	50
50	20	50	50	50
80	50	50	50	50

**Table 4**

4. Connect L1 and L2 on the MWH to L1 and L2 on the magnetic contactor using the wire size recommended for your unit. (See table 3).
5. Connect T1 and T2 to the load side of the magnetic contactor before the over load relay heater elements as shown below. Do not connect to the output terminals of the overload relay. Use the wire size recommended for your unit.
6. If your system utilizes a heater off-on switch, connect it in series with normally closed auxiliary contact on the motor starter to the terminals labeled "SW". Use AWG 16 wire for the circuit.
7. If your system does not utilize a heater off-on switch, connect the normally closed auxiliary contact directly to the terminals labeled "SW" (TB1). Note: The cover of the motor winding heater depicts the connection diagram (See wiring diagrams below).
8. If required, connect the normally open contact from the motor overload to the overload connection as shown on the wiring diagram.
9. Replace the cover when all connections have been completed and checked.

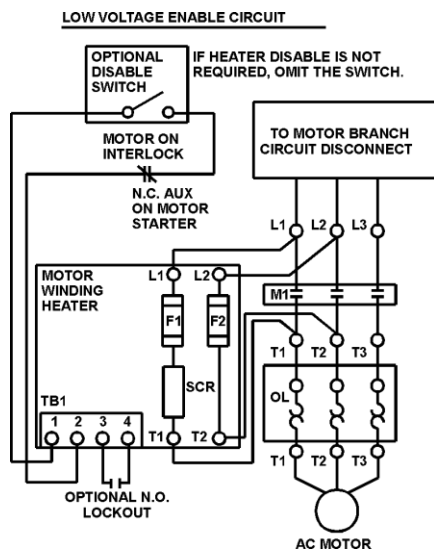

**Wiring Diagram for units rated at 10, 50 and 80 Amps**

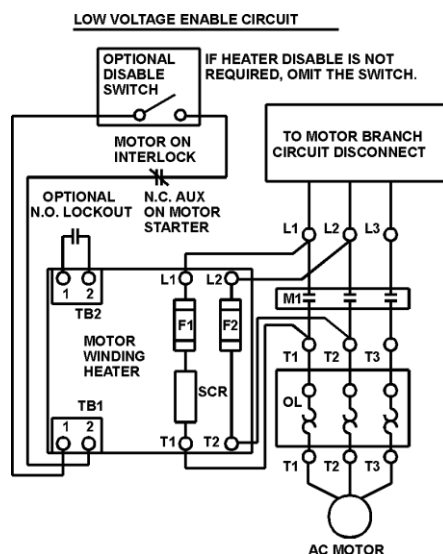

**Wiring Diagram for units rated at 25 Amps**

10. Included with each unit are two self-adhesive warning labels. Attach one warning label in a conspicuous place on the motor junction box and the other on the outside of the starter enclosure.

**WARNING**  
**THIS MOTOR IS EQUIPPED WITH A MOTOR WINDING HEATER. VOLTAGE IS PRESENT AT MOTOR TERMINALS EVEN WHEN MOTOR STARTER IS OPEN. BEFORE SERVICING MOTOR OR MOTOR WIRING ALWAYS DISCONNECT MAIN POWER AHEAD OF MOTOR STARTER.**

**Sample Warning Label**

11. If the motor winding heater is to be paralleled with a soft start, the customer must provide an isolation contactor between the output of the MWH and the motor as shown in the figure below.

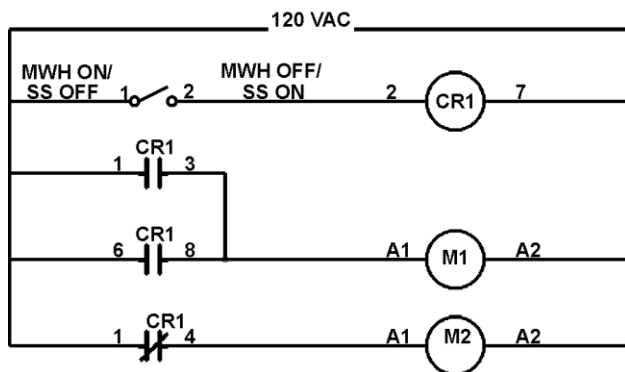
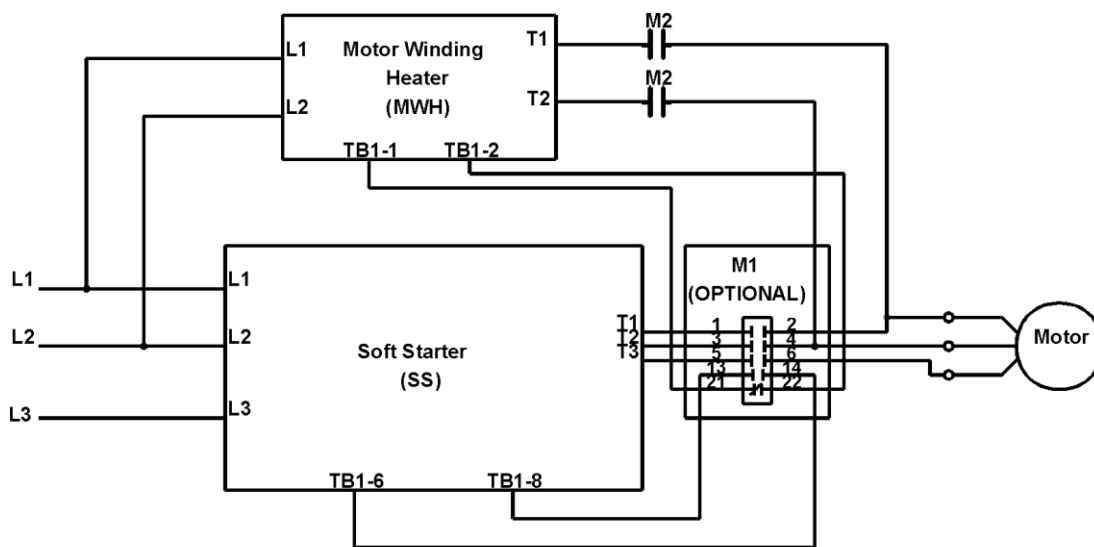

**Wiring Diagram for units rated at 25 Amps**

### 3.0 - Operation

1. Apply line voltage to the system. The “Power On” LED on the MWH should light. If the “Power On” LED does not light, it is an indication of a blown fuse or improper connections. Do not proceed until this is corrected.
2. If the motor starter is off and the “SW” circuit is closed, then the “Enable On” LED will be on. The MWH will turn on automatically in approximately 1 minute.
3. The “Output On” LED will turn on when the MWH begins to apply voltage to the motor.
4. The output voltage to the motor is factory set for 8% to 9% of the line voltage. (Measured with an RMS AC Voltmeter) Maximum range of this adjustment is approximately 15% of line voltage.

**Note:** Caution must be used when adjusting the output. Too high a setting may cause excessive heating in the motor.

5. During initial start-up monitor the output current to the motor. Use a DC clamp-on ammeter. Output current must not exceed the rating of the motor winding heater unit.
6. When the motor is starting the MWH automatically shuts off. It will remain off until the motor is turned off. The MWH will then turn on after approximately 1 minute.

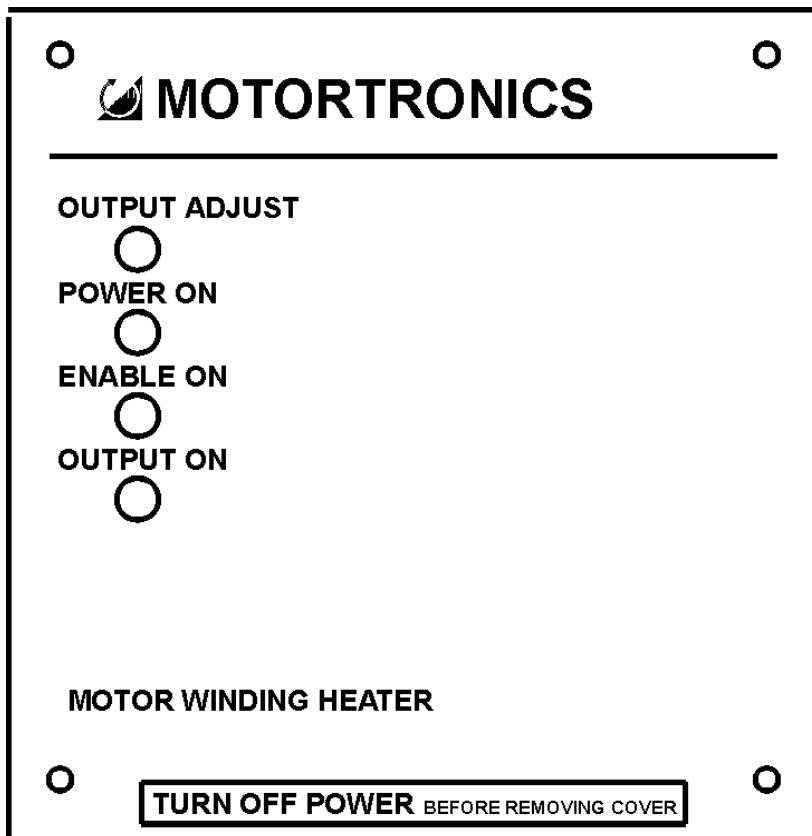

LED Placement

4.0 - Diagrams

4.1 MWH 10A Model

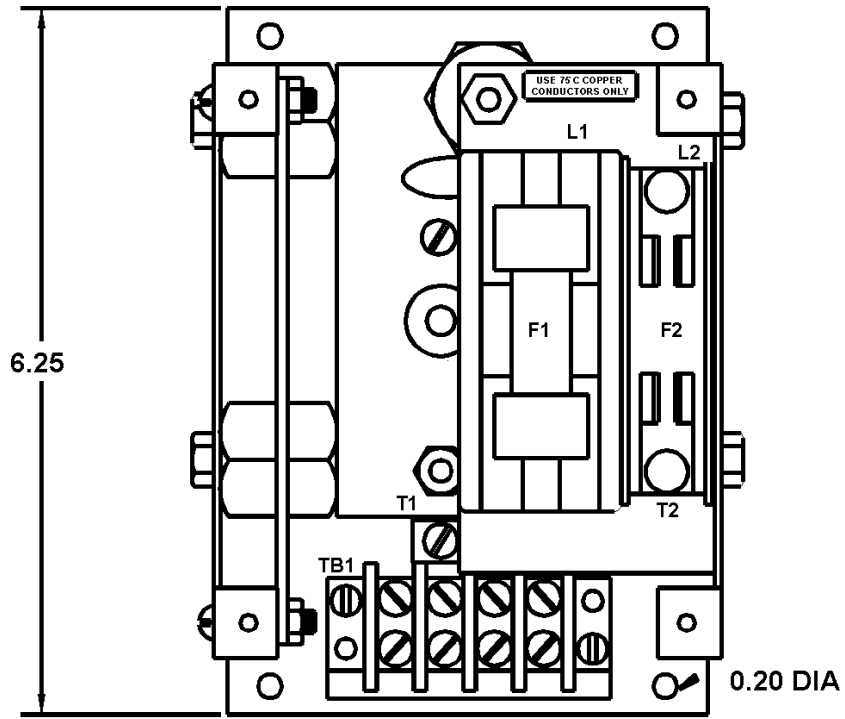

FRONT VIEW WITH COVER REMOVED

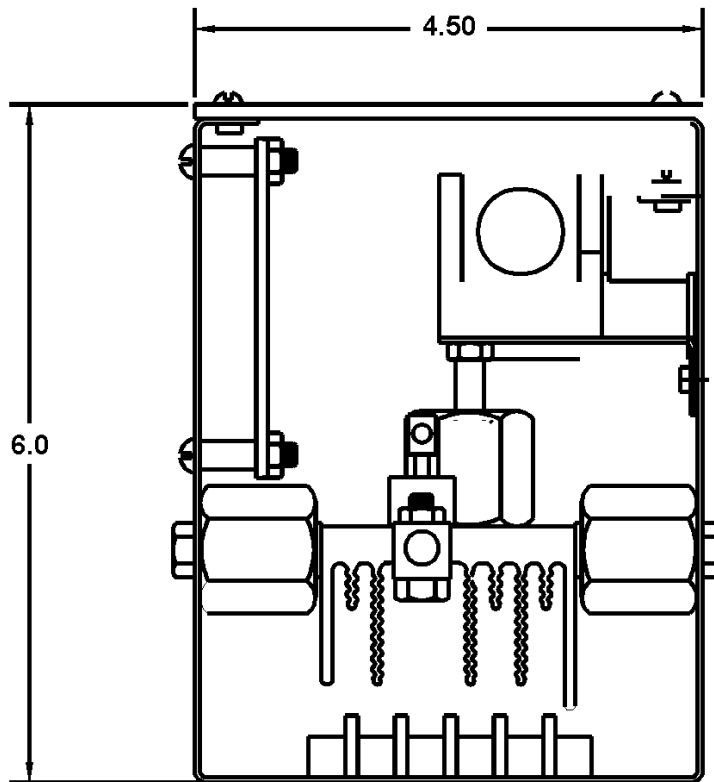

BOTTOM VIEW

4.2 MWH 25A Model

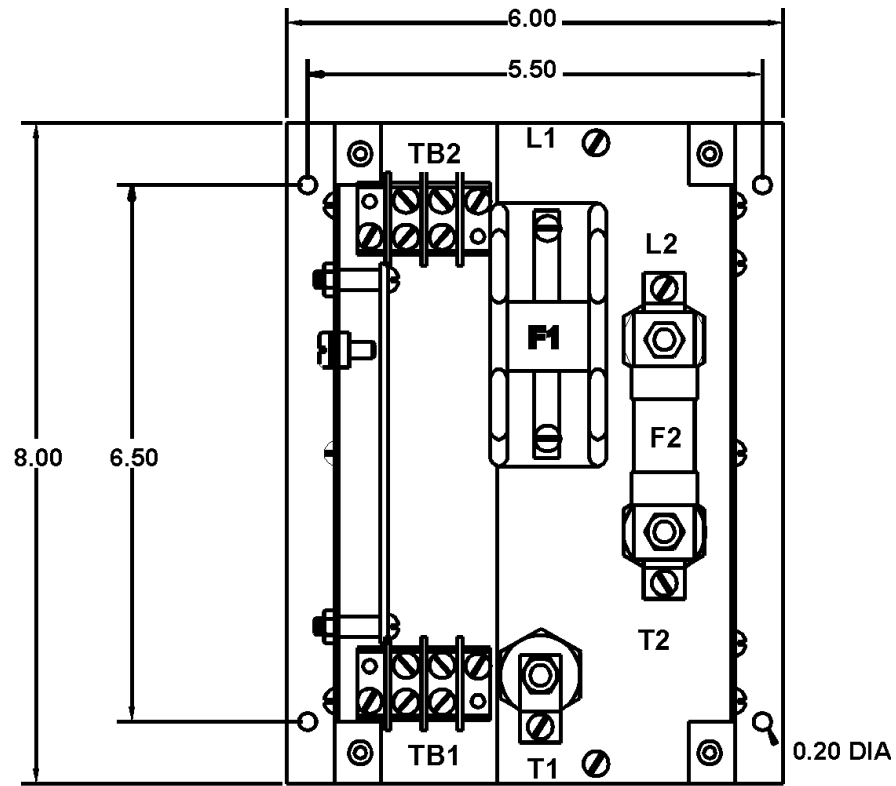

FRONT VIEW WITH COVER REMOVED

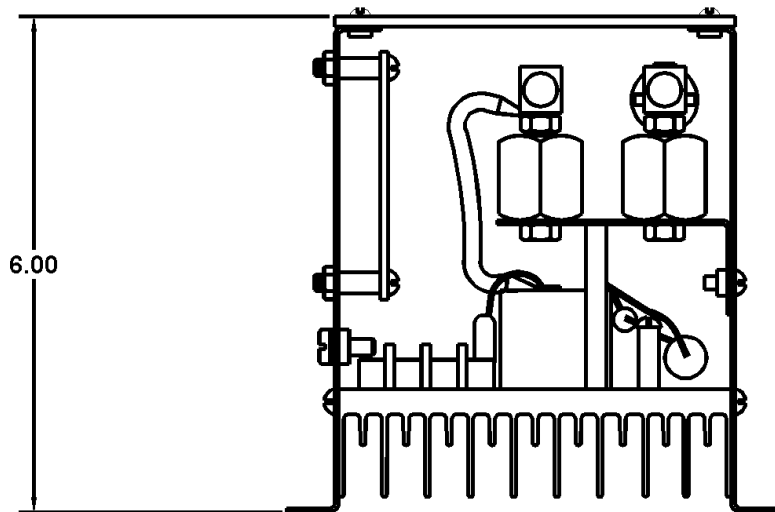

BOTTOM VIEW

4.3 MWH 50A Model

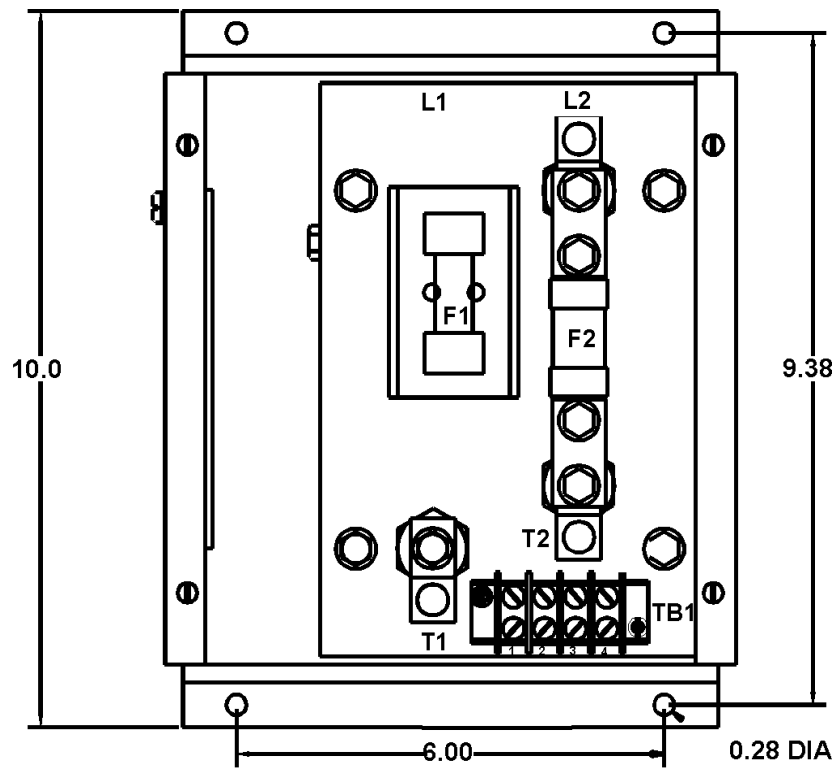

FRONT VIEW WITH COVER REMOVED

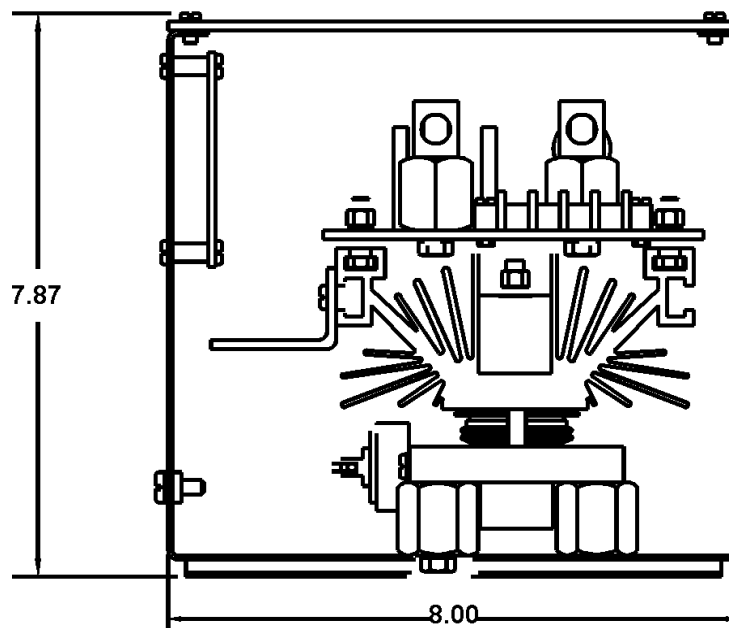

BOTTOM VIEW

4.4 MWH 80A Model

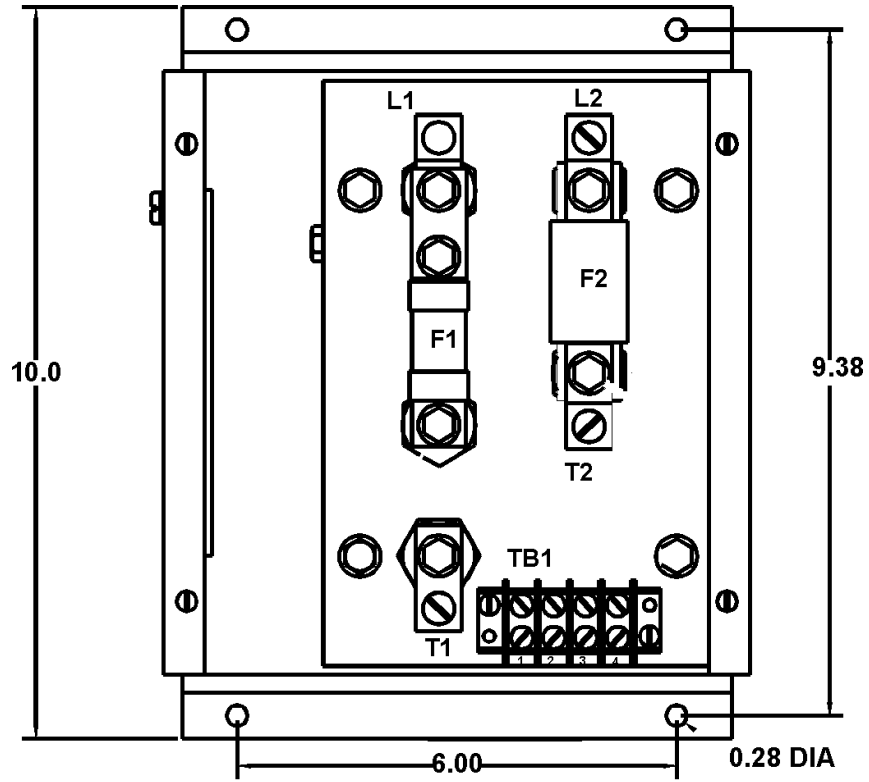

FRONT VIEW WITH COVER REMOVED

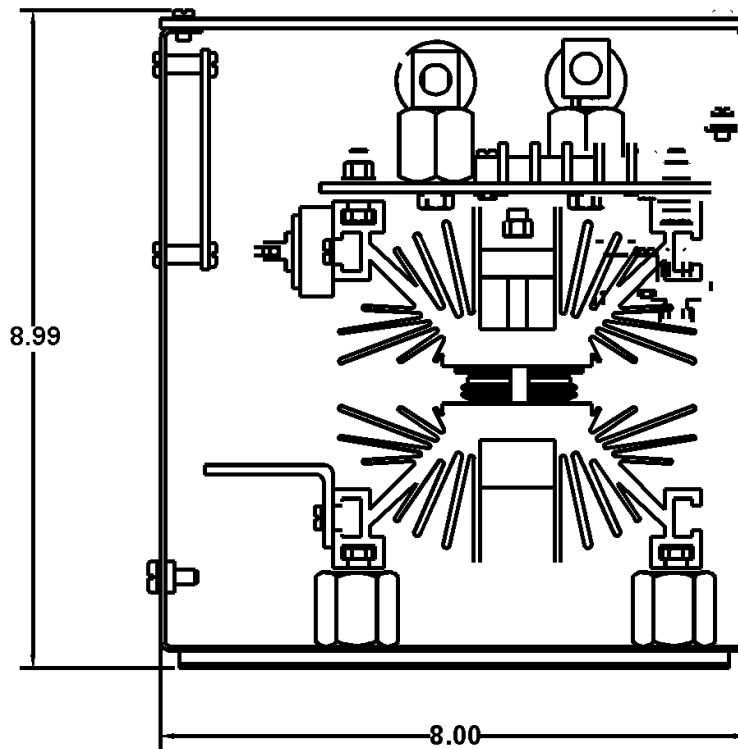

BOTTOM VIEW

**Warranty**

Motortronics warrants its products to be free from defects in material and/or workmanship for a period of one year from the date of installation of a maximum of 18 months from the date of shipment as indicated by the unit's date code. The company reserves the right to repair or replace any malfunctioning units under warranty at their option. All warranty repairs must be performed by the Company factory or on site by factory authorized service firms or personnel approved by the Company.

Solid state controls have different operating characteristics from those of electro-mechanical equipment. Because of these differences and the wide variety of applications for solid state controls, each application designer must verify that the solid state equipment is acceptable for his application. In no event will Motortronics be responsible or liable for indirect or consequential damages resulting from the use or application of this equipment. The diagrams and illustrations in this document are included solely for illustrative purposes. Because of the number of different applications, Motortronics cannot be responsible or liable for actual use based on the examples or diagrams.

**California Customers:****California Proposition 65 Warning**

WARNING: this product and associated accessories may contain chemicals known to the State of California to cause cancer, birth defects, or other reproductive harm. For more information visit <https://p65warnings.ca.gov>



# MOTORTRONICS™

Solid State AC Motor Control

# MWVH *Series*

## Heater Controller

Phasetronics, Inc. dba Motortronics  
1600 Sunshine Drive  
Clearwater, Florida 33765  
USA

Tel: + 727.573-1819 or 888-767-7792  
Fax: + 727-573-1803 or 800-548-4104

[www.motortronics.com](http://www.motortronics.com)